

THE SNAKESKIN

♣ Cobra Club of WA Inc ♣

Volume 1 Issue 4

26th August 1998

Page 1

A G M

What a hoot!!!

Well, what does A.G.M mean? Alcohol, Girls and Munchies – it must be, because what a bash it was, put on for the members by the Club.

I had never seen so much booze and food, plus the girls. O Boy!, the girls, how does our president know so many beautiful scantily clad young ladies and that blonde with the big hat – wow!! What a hat!!

Brief though it may have been, the meeting was very successful with all topics for discussion dealt with without any problems and the annual elections went off without a hitch – Congratulations to the newly elected committee. Now, back to the social gathering – Nah! It was a PARTY. With the DJ playing all the old rock n' roll hits from the 50's & 60's, the flashing coloured lights, sheep on the spit, the BBQ (great steaks, with a special thanks to the social director). The wine and beer was an excellent choice, although I must admit I did spill a lot, whilst trying to down a couple of magnificent steaks, but it was quickly mopped up by the topless cleaner. As the night went on, we all had a chance to dance with both the strippers, but the lucky President was the only one to get a kiss of the girls – lucky bastard.

The rest of the night was excellent – even blurry. So a big special thanks and a great well done to all the members of the social committee of the "Four-hole, mother of pearl, button collectors club of WA" and it ummm? Ohh!! Oops Oh! Sorry – wrong club AGM – apologies for that, should be about the Cobra club AGM my mistake – got carried away about another club's AGM.

cont.....pg 5.

Cobra Owners.....
Contact - Terry Lovell at

AUST.GUARD
Security Services

Alarm Systems

Hirsh Access Control

CCTV & Surveillance

Hire & Sales

Investigations & Debugging

Security Identification Systems

LIC 144/96 SAI
Suite 29
375 Hay St
Subiaco Mews
SUBLACO
6008

Ph. 9388 3898
FAX 089 388 3455



**THE FAMOUS
MOTOR CAR
COMPANY**

MOTOR VEHICLE
INSURANCE
FOR
VETERAN VINTAGE
CLASSIC &
COLLECTABLE CARS

THE HYATT CENTRE
87 ADELAIDE TCE
PERTH WA 6000

PH: 9221 8100
FAX: 9221 8122

"JUNK YARD DOGS"

Ever wondered what makes Junk Yard Dogs the way they are?

A clue is – it might be their owners. Being a car enthusiast I have often had the time to be in need of a secondhand car part for a repair on the family vehicle, or a part for a special project and in all the times I have dealt with wrecking yard people, have reached an opinion that they are rude, obnoxious and very aggressive – treating you with suspicion and contempt. They seem to think that if they show you the part in question and you don't buy it – all you are doing is casing the joint so you can sneak back after hours and pinch the said item – not because the part is probably worse than the one you are replacing or for only a few dollars more you can buy a new one.

Their phone manner is very good and friendly, although their description of a part's condition and value is some times bordering on fantasy.

Recently I was in need of carpets for a car and thought I would try the "Wreckers" for some. – My fingers did the walking on the phone and after 30 minutes had found two that had some, both were described as very good conditions just need a bit of a clean, Unfortunately both yards were a long way from home – so a journey was prepared for the Saturday morning.

Carpet No.1 - the people at the counter were very friendly and remembered my call, so they fetched the carpet to the counter and laid it on the ground before me – explaining the best ways to remove the large black oil stains and the most effective means of covering the hole worn under the driver's foot was to "put a mat on it" and the carpets for this model are indeed very rare and expensive.

...cont page 5

QUOTE FOR THE MONTH : "I don't know the key to success, but the key to failure is to try to please everyone."Bill Cosby. (ex Cobra owner)

Cobra II on target

US racing legend Carroll Shelby says he's on target to have his first production Series 1 supercar on the road this summer.

"This is going to be one world-class ass-kicker," explains the 75-year-old ex racer. Shelby plans to build 500 of the 242kW roadsters over the next two years, \$US100,000.

With less than four months to go, ol' Shel claims that the Series 1 –the spiritual successor to the legendary Shelby Cobra –has hit two major goals. First, it will run standstill to 100 km/h in under five seconds, and second, its carbon fibre bodyshell, with mechanicals, will tip the scales at less than 450kg.

Power for the Series 1 comes from a modified version of the 32-valve 4.0-litre Oldsmobile V8 that's used in the Aurora saloon. To improve handling balance, Shelby switched from a Richmond six-speed gearbox bolted to the back of the engine, to a ZF six-speed transaxle at the rear of the car.

Mounted to the aluminium space-frame chassis is full race car suspension, with double wishbones all-round and fully-adjustable, inboard-mounted coil/damper units working on rockers.

Howard Walker

(A recent article from MOTOR Mag, 6/98)

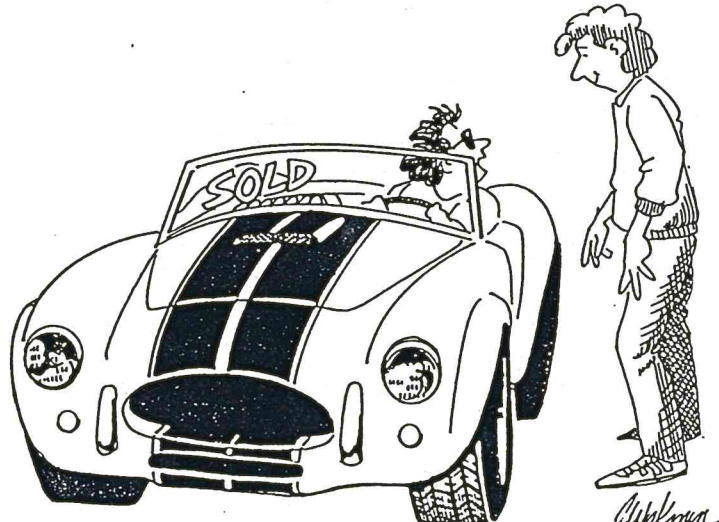

Oh yeah, lots and lots and lots of pretty pennies!

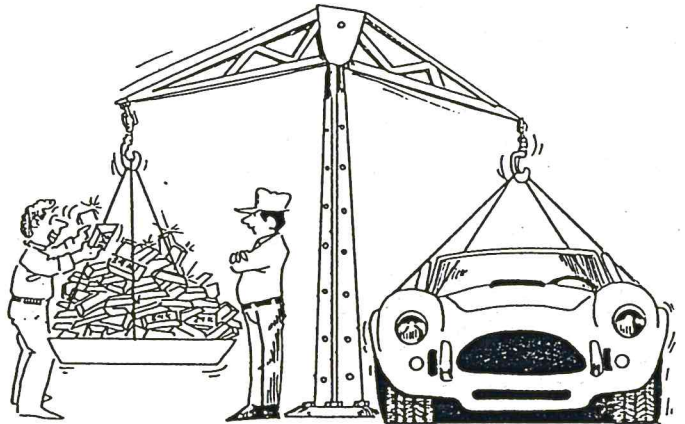

Come up with just a little more and I think we may just have a deal.

DREAMERS CORNER

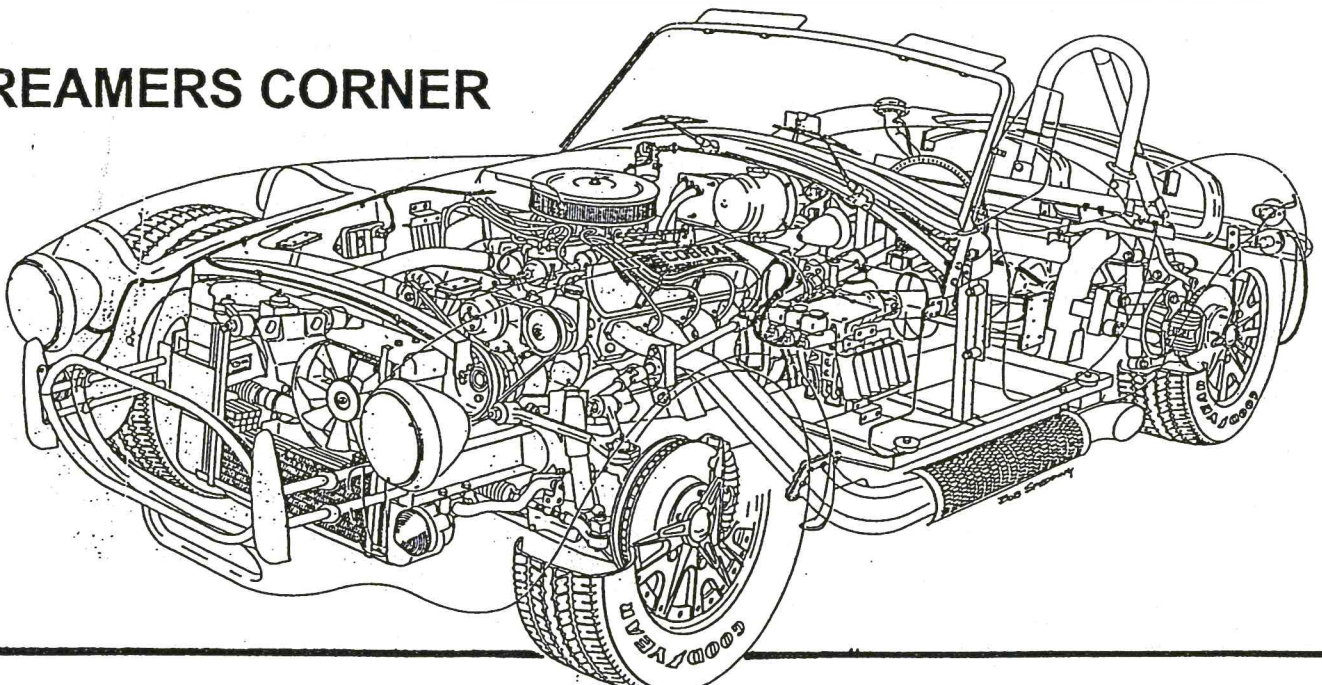

...continued from page 1 AGM

The Cobra Club A.G.M. went well – even though we couldn't have our elections as we only had 22 members present . A special thanks to Yvonne for the tea & biscuits. I am looking forward to the next AGM – of the button collectors club?

The Editor
Harry Mac

"Junk Yard Dogs" ...cont from page 1

Needless to say I didn't want it and thanked them for their time and effort and left them mumbling to each other – at which I can only guess as to what nice things they were saying about me.

Carpet No.2 – I had saved the best carpet description for last. The sad looking old man at the counter was again friendly and courteous and explained that as he was the only one there and couldn't leave the office, so asked if I didn't mind too much, would I go out the back and look at it for myself. I agreed and promptly headed for the yard. I found a grey car that was the same model, that had been well and truly rolled and I mean more than twice. It made me wonder as to the occupants survival, the carpets in the car were ripped, full of glass, sand, oil and obviously being full of water from sitting there through a few winters judging by the mould at the top of the water line. I wandered around looking for the car with the "very good" carpet – but no luck so I returned to the office to get more accurate directions, only to be told – "I must need glasses if I didn't see the rolled grey one over by the fence and was told the carpet was fine – it just needed to be dried out."

So I politely thanked him for his effort and wished him a "Nice Day" - to which he said "What did you say that for"? And I gave him the reply "Because you look like you bloody need one"!

Harry Mac
Editor



J. Watman

This is it. . . . Everything else is on back order.

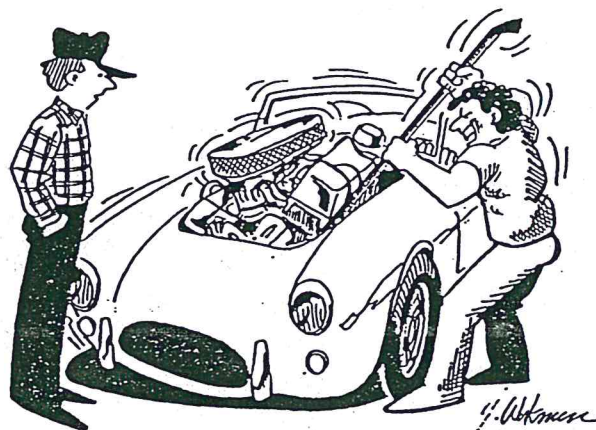

J. Watman

" I TOLD YOU WE COULD FIT THE V -10 IN THERE, DIDN'T I ."

ARROW ENGINEERING.....quote.

SHANNONS

**INSURANCE
AGENTS & AUCTIONS**

**SPORTS
CLASSICS
VETERANS
VINTAGE
MODIFIED
CARS & BIKES
COMMERCIALS**

135 GT. EASTERN HWY.
BELMONT 6104.
PH 94793555.



ARROW ENGINEERING

GENERAL ENGINEERS

*Fitting & Machining
Welding & Gear Cutting.*

COBRA CHASSIS
modification to order.

*Servicing Requirements to builders
of Specialised Vehicles.*

See **GRAHAM SACH** at
28 **TAMBULAN** Way
MAIDA VALE 6057.
Ph. / Fax 94543972

FOR SALE

Ford 302C Complete
Ford 351C Short & Clutch
 Std Bore??
Toyota 5 Speed Gearbox.

Dave Tadic
Ph. 94547064

Ford 351W
Assorted Parts
Chrome Rims Steel 15"x7"x2
Jag Rear Springs x 4
Spax Shocks Fr. / Rear .x 2
Koni Shocks & Springs x 2
Monroe Gas Shocks x 4
Yokohama 352. 50%
295 x 15 x 50 Series.

Peter Coleman
Ph. 93373255

Ford 460, with bellhousing to
suit Toploader. Full recon, never
started. Harry Prince.
93534959

ATTENTION !!!

SPRAYPAINTERS / BEATERS / DIY's

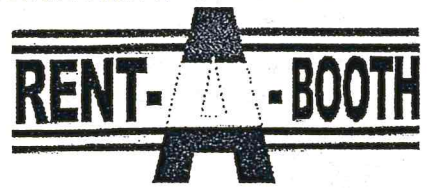

BAKING OVEN TO RENT

- DOWNDRAFT/PRESSURIZED OVEN
- Need HELP - Book our Pro painter
- LARGE - 7m X 4m
- PAINT AVAILABLE ON SITE
- SPECIAL TOW RATES

FROM ONLY
\$50

OPEN
7 DAYS

PHONE NOW

TO BOOK

9227-5000

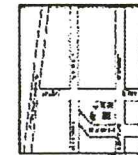

622a NEWCASTLE STREET, LEEDERVILLE, PERTH

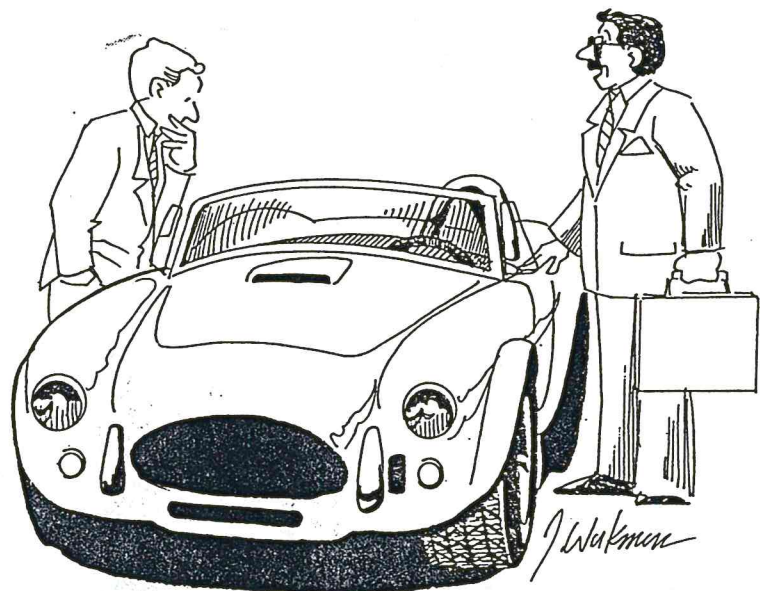

Why shouldn't an investment portfolio be fun?